

Наименование деталей

1. Боковина левая	923x323	1 шт.	5. Полка	298x167	2 шт.
2. Боковина правая	923x323	1 шт.	6. Ригель	170x167	1 шт.
3. Полка стац. верх.	323x168	1 шт.	7. Стенка МДФ	600x176	1 шт.
4. Полка стац. нижн.	323x168	1 шт.	8. Стенка МДФ	299x176	1 шт.

Необходимый инструмент

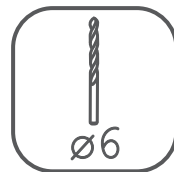
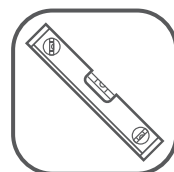

Установите на шуруповерте минимальные обороты!

Фурнитура в комплекте

	а		б		в		г		д		е		ж
Евровинт 50	13 шт.	Загл к ев.винту	13 шт.	Загл. самокл. Д14	11 шт.	Загл самокл. Д20	7 шт.	Стяжка 30 мм	3 компл.	Навес клямер	2 шт.	Шкант дерев 8x30	8 шт.
	з		и		к								
Шуруп 4x16	4 шт.	Эксцентрик 16	2 шт.	Дюбель 30 мм	2 шт.								



Рис. 1



Рис. 2

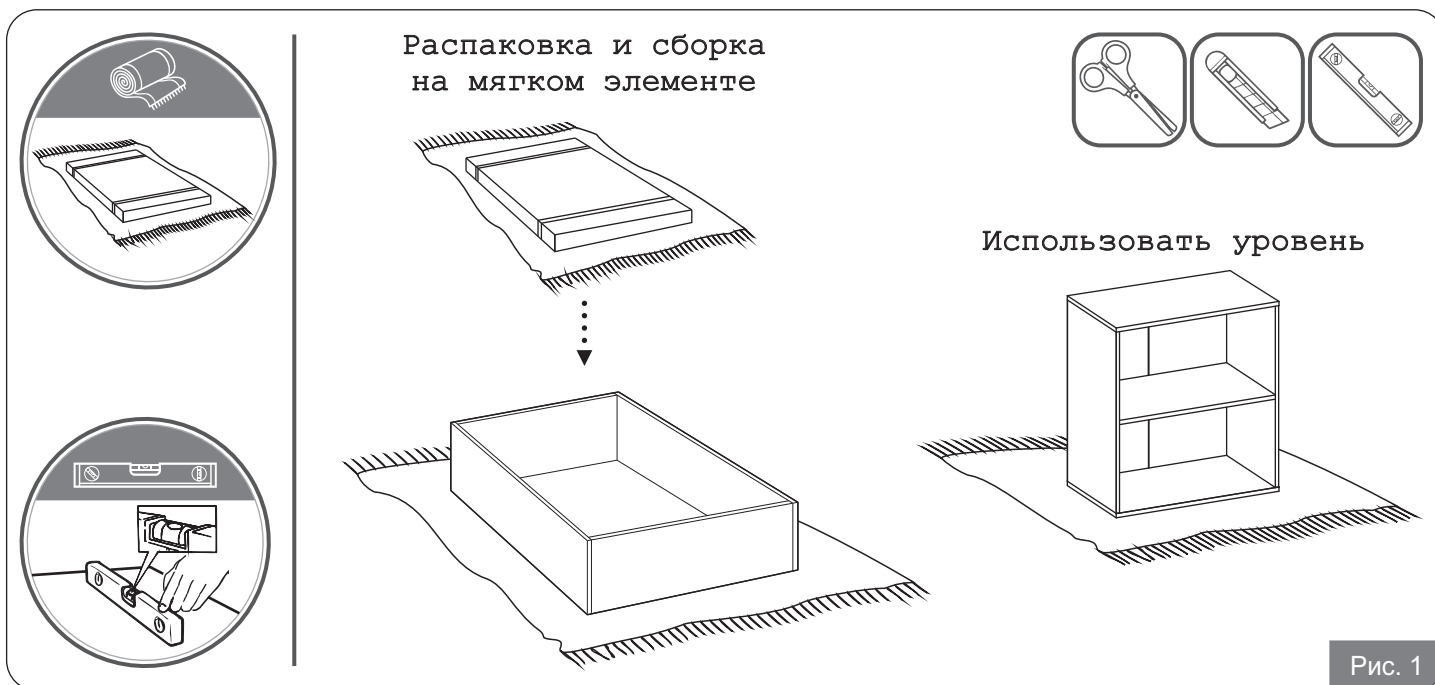

Рис. 3

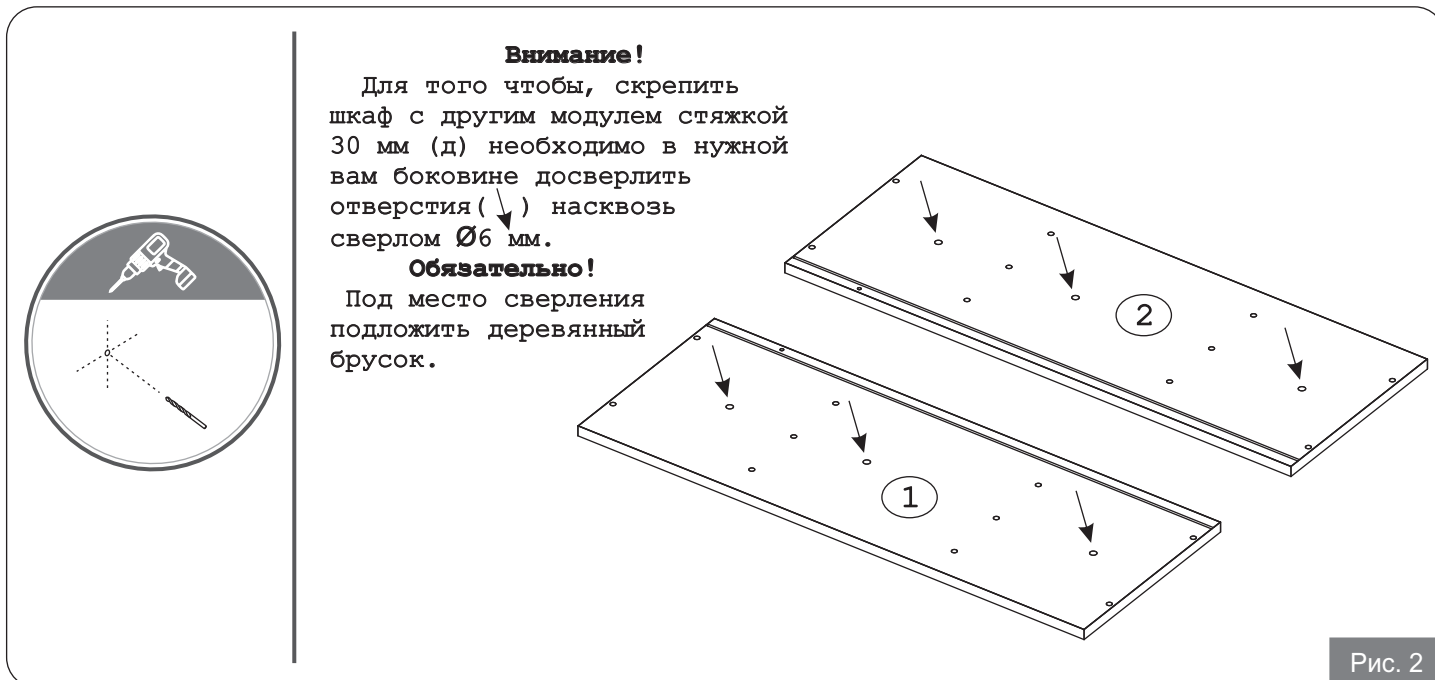

Рис. 4

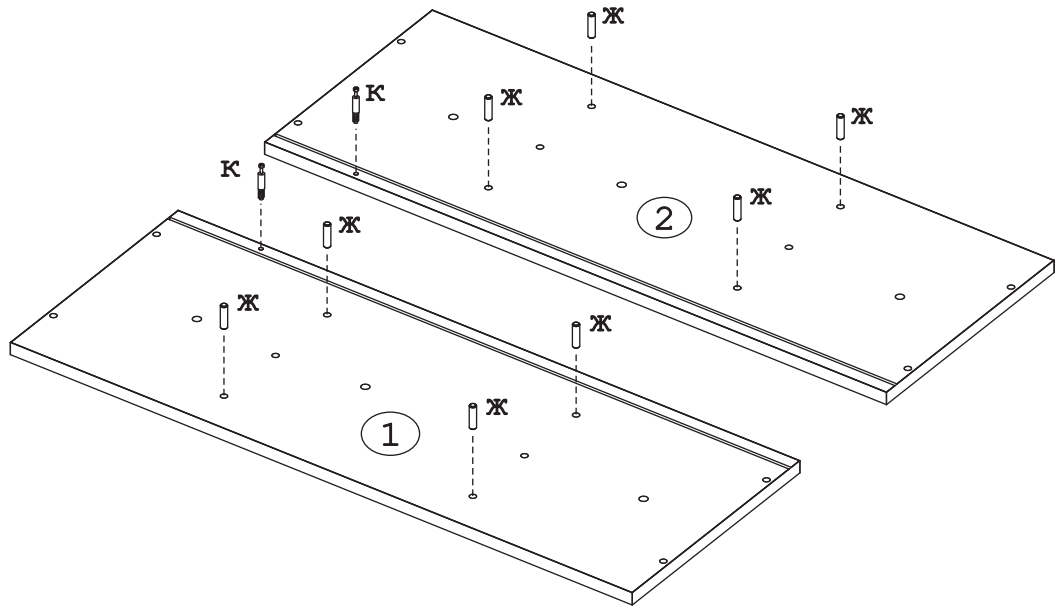
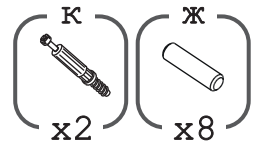
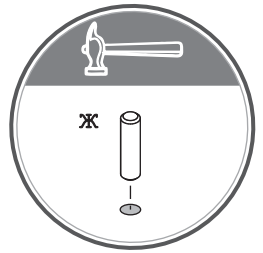
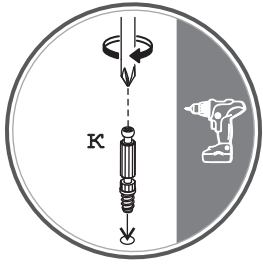

Рис. 5

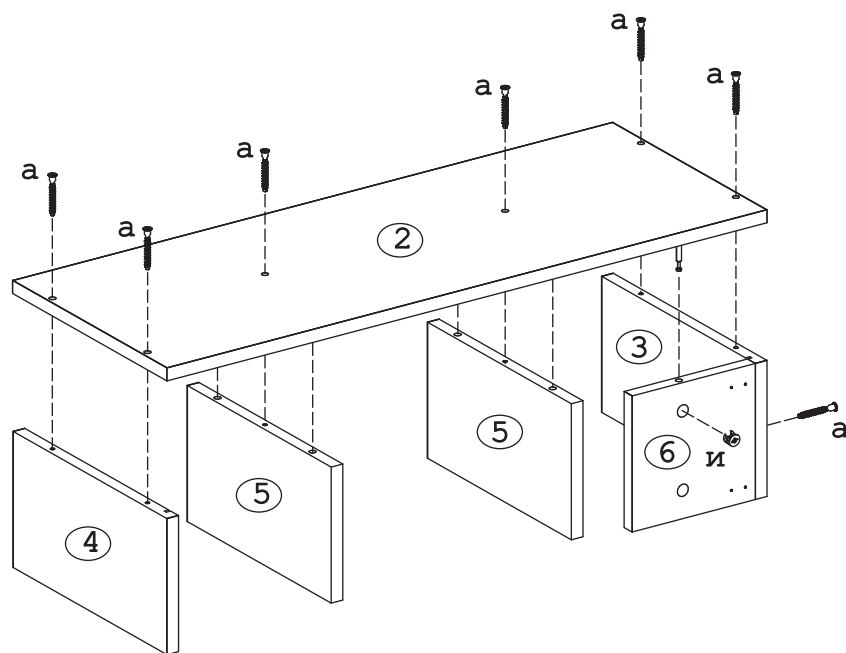
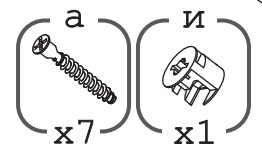
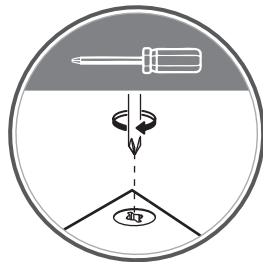
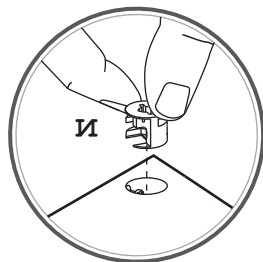
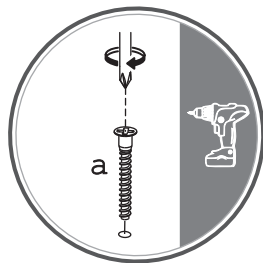
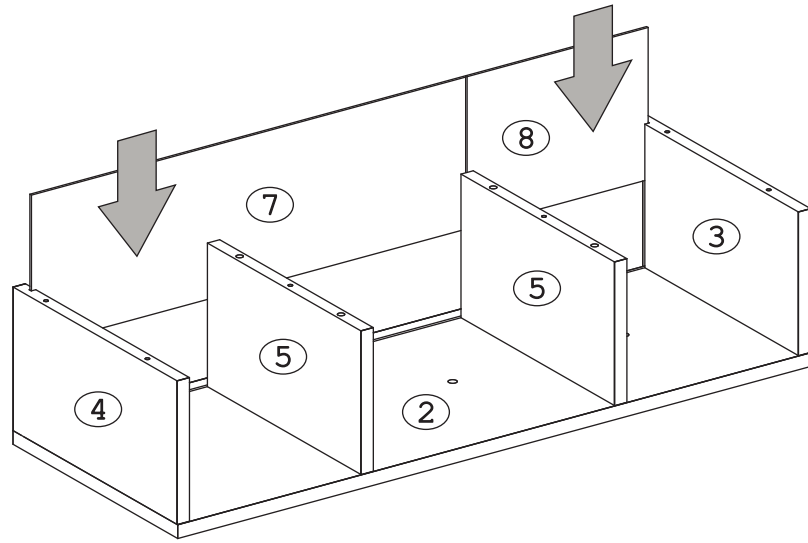
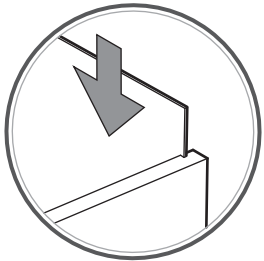
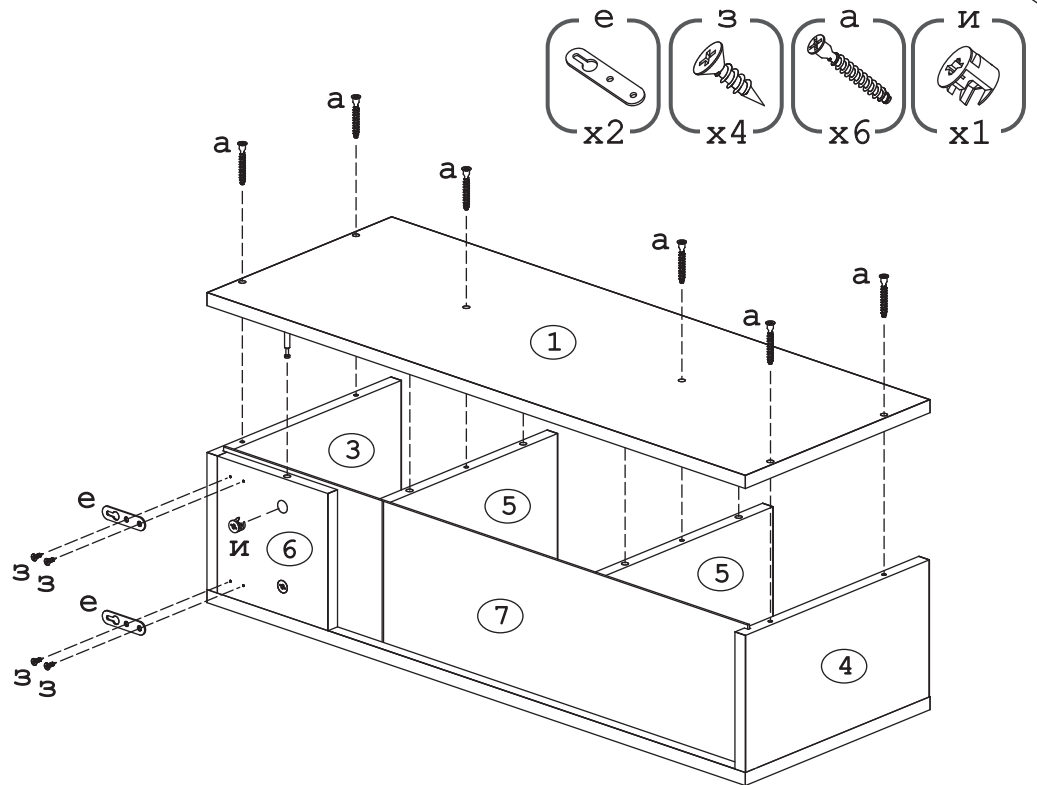
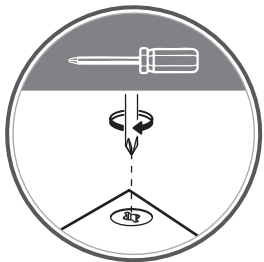
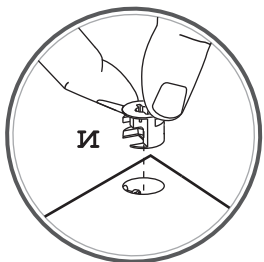
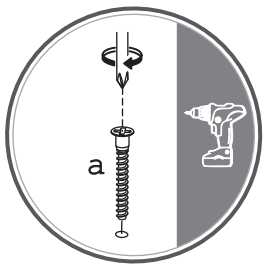

Перед креплением модуля навесы
клямер (е) отогнуть отверткой.

Рис. 6